

# TK Absolute Power / Energy

## Meter System

### *Installation and Operating Instructions*

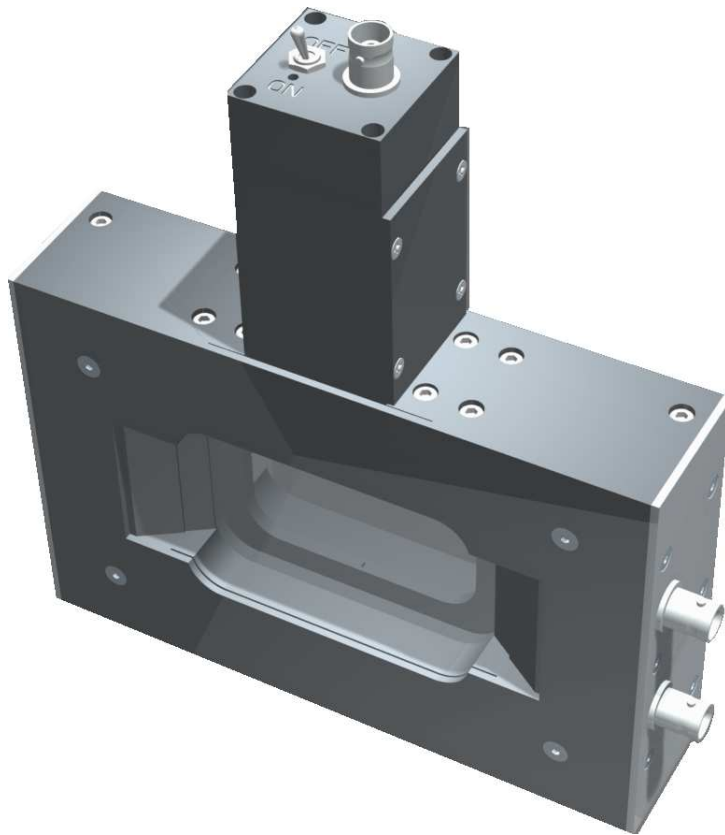

2<sup>nd</sup> November 2009  
Software version 3.1

Thomas Keating Limited  
Station Mills, Daux Road  
Billingshurst, West Sussex  
RH14 9SH, England

Phone +44 (0)1403 782045  
Fax +44 (0)1403 785464

<http://www.terahertz.co.uk/>

# Precautions

## NI-DAQ Software Installation

The supplied NI-DAQ software must be installed before connecting the support unit to a PC.

- Ensure that you are logged into the PC as an administrator.
- Install the NI-DAQ software following the instructions in [section A.2](#).

## Film Overload

To avoid damage to the metal film within the power meter head, the signal strength must not exceed the following limits, spread over the 40 mm window aperture:

- **Continuous wave power:** 500 mW
- **Pulsed energy:** 100 mJ at a 5 Hz repetition rate

If the beam power is to be concentrated in an area significantly smaller than the aperture, these beam power limits should be correspondingly reduced to avoid local damage of the film. Films have been damaged by relatively small levels of power applied over very small areas.

# Contents

<b>Precautions</b>	<b>i</b>
<b>1 Introduction</b>	<b>1</b>
1.1 The System . . . . .	2
1.2 Principles of Operation . . . . .	4
1.2.1 Positioning . . . . .	5
1.2.2 Modulation . . . . .	6
<b>2 The Support Unit</b>	<b>8</b>
2.1 Setting Up . . . . .	9
2.2 Software Configuration . . . . .	12
2.3 Calibration . . . . .	15
2.4 Measurement . . . . .	18
2.5 NEP Estimation . . . . .	19
<b>3 Stand-alone Usage</b>	<b>21</b>
3.1 Power Measurement . . . . .	22

3.1.1	Setting Up . . . . .	22
3.1.2	Calibration . . . . .	22
3.2	Energy Measurement . . . . .	24
3.2.1	Setting Up . . . . .	24
3.2.2	Calibration . . . . .	24
3.3	External Responsivity . . . . .	27
<b>4</b>	<b>Troubleshooting and Maintenance</b>	<b>28</b>
<b>A</b>	<b>Software Installation</b>	<b>30</b>
A.1	PC Requirements . . . . .	31
A.2	NI-DAQ . . . . .	32
A.3	Support Software . . . . .	38
<b>B</b>	<b>Window Transmission</b>	<b>40</b>
B.1	Factory Measurements . . . . .	41
B.2	Measurement Method . . . . .	41
B.3	Broadband Transmission . . . . .	44
	<b>Acknowledgements</b>	<b>45</b>
	<b>Index</b>	<b>46</b>



# **Chapter 1**

## **Introduction**

## 1.1 The System

The TK Terahertz Absolute Power Meter System is an auto-calibrating power meter for use with free-space beams in the frequency range from 30 GHz to 3 THz.

### Components

- This manual
- **The power meter head** (may be purchased separately) which is a photo-acoustic detector using a closed air-cell and a pressure transducer. Calibration is provided by ohmic heating of a thin metal film within the cell.
- **The support unit** is based upon a National Instruments 'USB-6211' data acquisition module encased in metal box. Additional electronics have been added to provide film heating for calibration and amplify the signal from the head's microphone pressure sensor.
  - NI USB-6211 based module
  - 1 USB cable
  - 2 BNC cables
  - 2 NI CDs containing the NI-DAQ software
  - 1 CD containing the power meter software

### Specification

- The sensitive area of the system is greater than 30 mm in diameter
- The system has a typical NEP of about  $5 \mu\text{W}/\text{Hz}^{1/2}$
- For energy measurement the typical NEJ is about  $1 \mu\text{J}$

**Software features**

- Automatic calibration
- Frequency dependent window loss correction
- A set of routines which trap equipment and operator errors

## 1.2 Principles of Operation

The power meter system measures power in a beam directed into the head window. The head comprises a closed air-filled cell formed by two closely spaced parallel windows with a thin metal film in the gap between them. A known fraction (close to 50%) of the power of the incident beam is absorbed in the metal film, the remainder being partly transmitted through the cell and partly reflected from it.

The beam must be 100% amplitude-modulated either at its source or by a chopper placed in the path of the beam. The modulation frequency is to be in the range 10 Hz to 50 Hz, and the lowest NEP is found in the middle of this range. Ideally this modulation should be square-wave as the calibration process is based upon a square-wave modulation.

The absorption of the power in the film produces modulated variations in the temperature of the film and the layers of air in contact with it. In turn this produces a modulation of the pressure in the cell, which is detected by a pressure-transducer, measured by the lock-in amplifier and displayed on the PC. The modulated pressure change is closely proportional to the total absorbed power; it depends negligibly on the distribution of the absorbed power over the film.

The power meter can be calibrated by dissipating a measured amount of ohmic power in the film. A modulated current is passed through it via electrodes that contact opposite edges of the film. As shown in [Figure 1.1](#) the head unit provides two independent connections to the electrodes to allow the applied voltage to be sensed accurately. To calculate the power produced, the resistance of the film,  $R_{\text{film}}$ , must be known. This should be measured using a digital multimeter via one of the two BNC coaxial cable connectors on the side of the power meter head.

The absorption of the window is close to zero at 100 GHz but increases with frequency — see [Appendix B](#). The support software includes a look-up table giving the window-loss as a function of frequency based upon TK's laboratory measurements.

### 1.2.1 Positioning

The power meter head should be placed in the beam where the beam width is small enough to be clearly accommodated within the aperture of the window. This may require the use of a lens or mirror to condense the beam to a beam-waist at the power meter head.

To make power measurements which are free of frequency-dependent calibration errors caused by reflections from the windows, the power meter head should be used at the Brewster angle. There are no reflections from the window if the power meter head is set so that the beam is incident at the Brewster angle ( $55.5^\circ$ ) with the plane of polarisation in the plane of incidence, as shown in [Figure 1.2](#). That is to say the angle between the beam axis and the normal to the window should be  $55.5 \pm 5^\circ$ . If the E-field of the beam is in the horizontal plane the meter can simply stand on its base; otherwise an appropriate support wedge for the meter will be required. If the beam is not linearly polarised it is necessary to use a wire-grid polariser in the beam and measure separately the power in the two orthogonal linearly polarised signals.

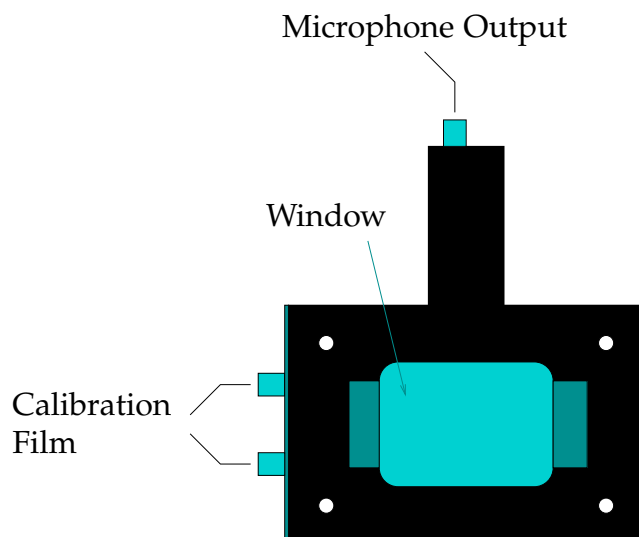

Figure 1.1: Sketch of the power meter head identifying the BNC connectors and window aperture.

## 1.2.2 Modulation

If the source of the beam can be switched on and off electrically within about 1 ms, good square-wave modulation at 10–50 Hz can be produced at source. If the source cannot be modulated in this way, a mechanical modulator in the form of a rotating bladed shutter (a “chopper”) should be placed in the beam path. To approximate square-wave modulation the width of each blade in the chopper would have to be much larger than the width of the beam at the modulator. In practice, the need to limit the size of the modulator will result in some deviation from the ideal square-wave form, and the power meter will tend to underestimate the signal power. To assess the level of error that might be incurred, an extreme case can be considered, namely modulation of sinusoidal form with a peak value corresponding to the unobstructed beam (i.e. the beam power). In such a case, the power meter will underestimate the beam power by 26%. In practice, of course, the modulation will usually be much closer to the pure square-wave and the error incurred very much less.

If a mechanical chopper is being used, care should be taken to ensure that it does not modulate infrared and visible light. The head windows transmit infrared and visible light and the power meter will detect any changing or modulated power at these wavelengths incident upon it. The head will also respond to air pressure fluctuations at the reference frequency, perhaps generated by the modulator blades. To reduce false signals of these kinds it may be necessary to introduce a baffle at the modulator with an aperture in it to pass the beam. Black polyethylene across the window aperture can also be used to reduce significantly IR and visible radiation entering the head. The reduction in signal level

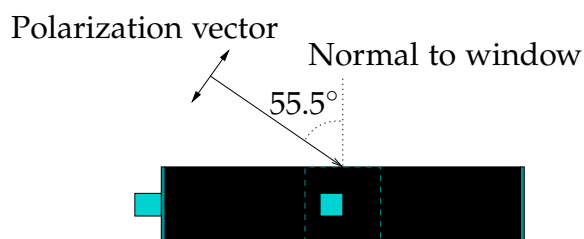

Figure 1.2: Sketch showing the head aligned at the Brewster angle to the incoming beam in order to minimize reflections from the window.

from the power meter when a second, similar, sheet is added will provide a measure of the attenuation in the first sheet, so that a correction can be made to the displayed power to compensate for the attenuation.

## **Chapter 2**

# **The Support Unit**

## 2.1 Setting Up

1. Following the NI-DAQ software installation (see [section A.2](#)), connect the USB port of the support unit to your PC, and after a few seconds a green LED light should start to flash on the hardware.
2. A message ([Figure 2.1](#)) should appear on the screen indicating that the data acquisition device has been detected.
3. To configure and test the device, open the NI-DAQ Measurement & Automation Explorer application — see [Figure 2.2](#).
4. In the tree view at the left hand side of the window, open Devices and Interfaces → NI-DAQmx Devices. This should include an entry for the NI USB-6211 device, showing that the drivers have been successfully installed.
5. The support software will, in its default configuration, expect the device connected to the power meter to be named “Dev1”. If necessary, it can be renamed at this point.
6. Connect the source of modulation (chopper or electrical) to the BNC connector labelled REFERENCE. The reference voltage should be TTL,

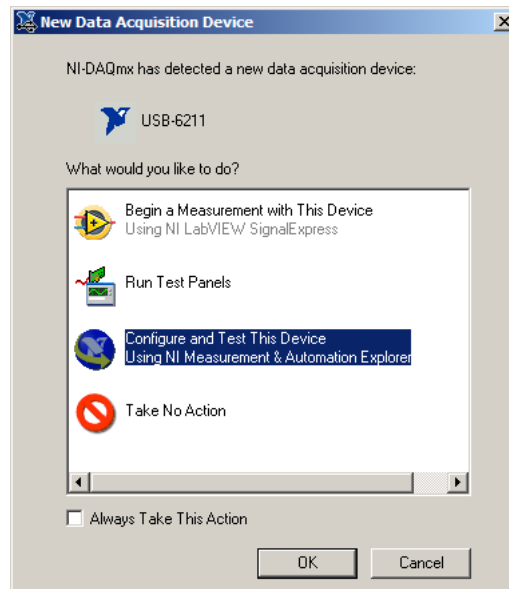

Figure 2.1: Pop-up window on device detection.

that is a square wave from 0 V to +5 V. The lock-in amplifier will work with lower voltages but is unable to lock into signals less than 1 V.

- Using one of the BNC cables supplied, connect the pressure transducer BNC output on the top of the power meter head to the BNC connector labelled SIGNAL, as shown in Figure 2.3. The second cable should run from one of the two film heating connections on the side of the power meter to the BNC cable labelled HEATER.

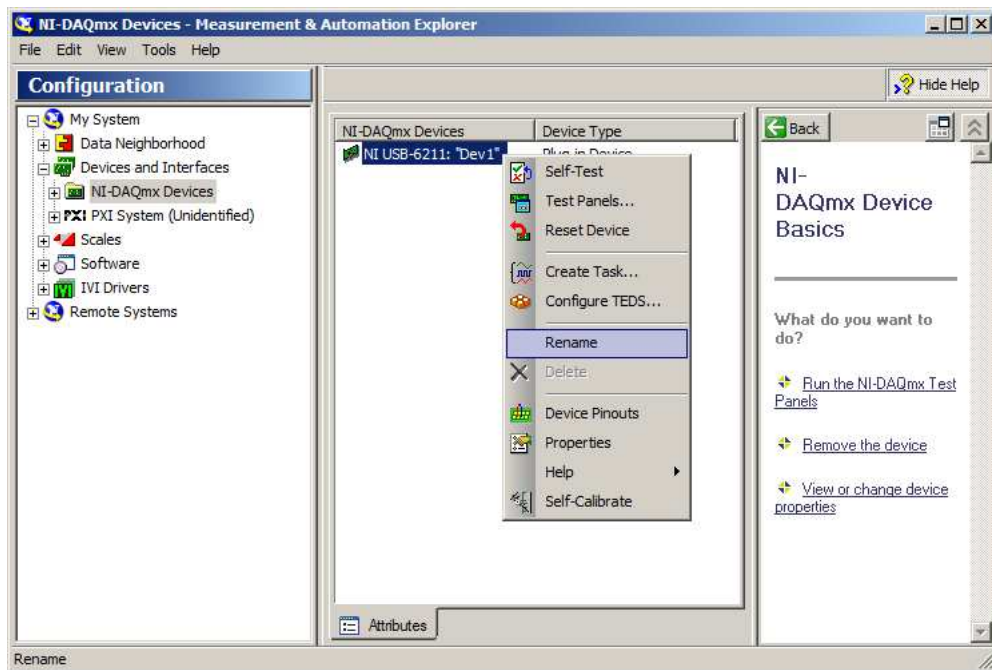

Figure 2.2: NI-DAQ Measurement & Automation Explorer, with menu options to rename a device and to perform a self test.

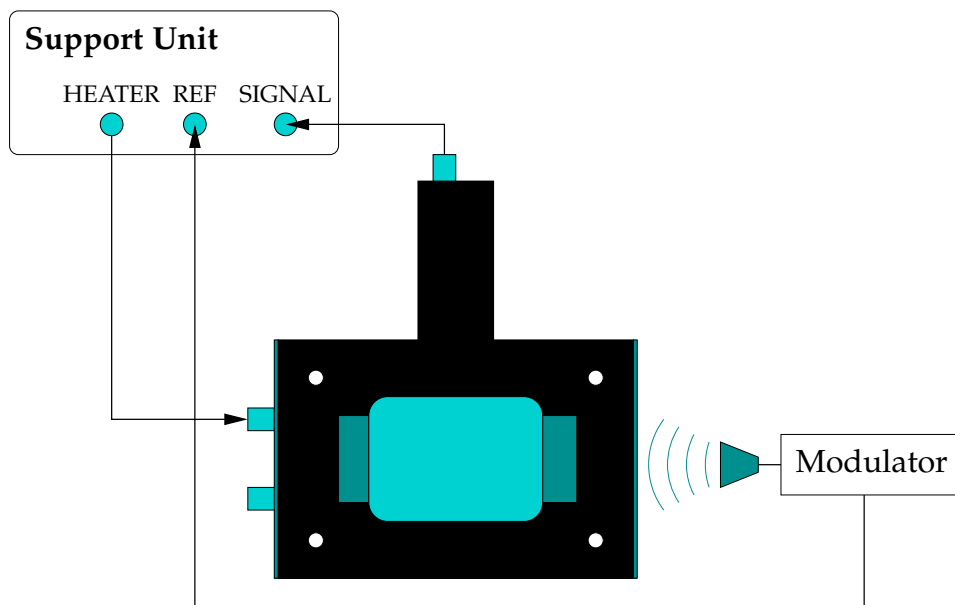

Figure 2.3: Schematic of the apparatus: connecting the TK power meter head, the support unit and the source of frequency modulation.

## 2.2 Software Configuration

The measured value of the film resistance needs to be included and saved in the configuration file before proceeding with measurements. This can be done through the following steps:



1. The power meter software is started by double-clicking on the shortcut icon, labelled 'TK Power Meter', on your PC desktop, or by selecting TK Power Meter → Power Meter from the start menu. This brings up the power meter front panel as shown in Figure 2.4.
2. The software starts automatically in calibration mode. From the menu button click Idle (Stop) to halt the measurement procedure.
3. Erase the name of the configuration file, PM TK-07 config dev1.ini,

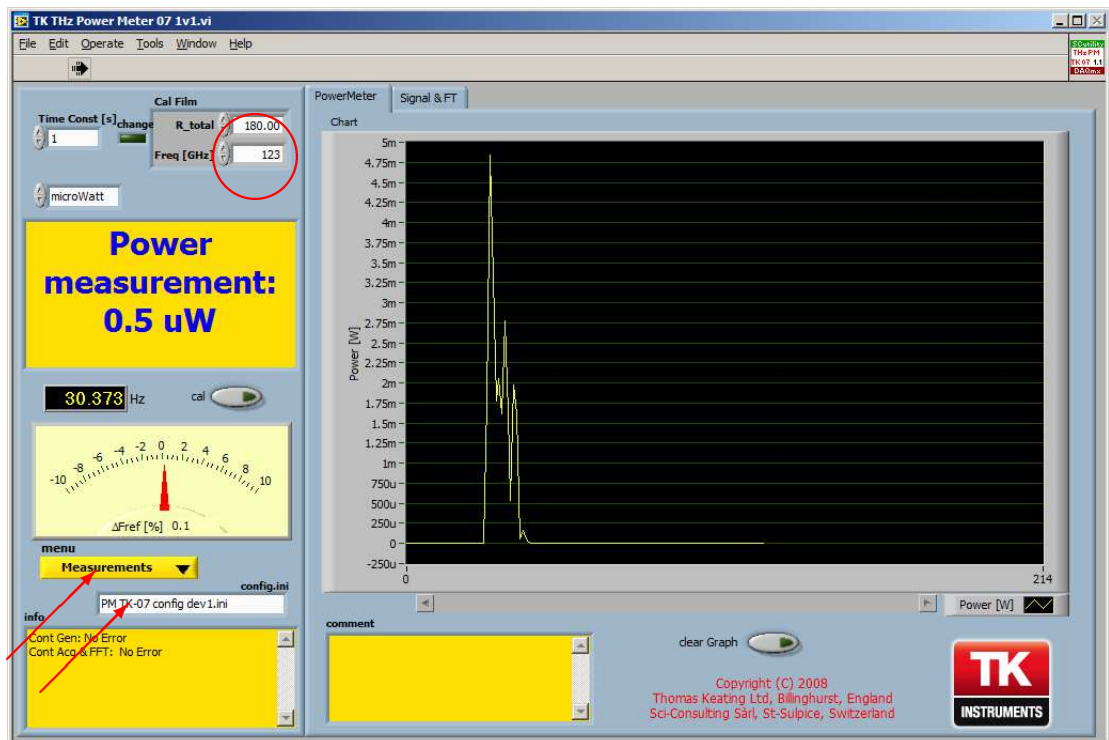

Figure 2.4: Support software main window. The arrows indicate the location of the menu button and configuration file name. The signal frequency input is circled.

from the input box indicated by an arrow in Figure 2.4.

4. From the menu button click on Initialize. Doing this with no file name specified causes the configuration window to pop up as shown in Figure 2.5. The configuration file includes pre-calculated values of resistances, voltages and timings for the system.
5. Adjust the value of film resistance, labelled  $R_{total}$  (indicated by a red circle in Figure 2.5), to match the measured value,  $R_{film}$ . If measurements will typically be made at one signal frequency, this can be saved in the configuration file (as Freq [GHz]) to avoid having to re-enter it whenever the software is started.
6. Click on the save button and choose the filename of the existing .ini file. Then click Replace to confirm.

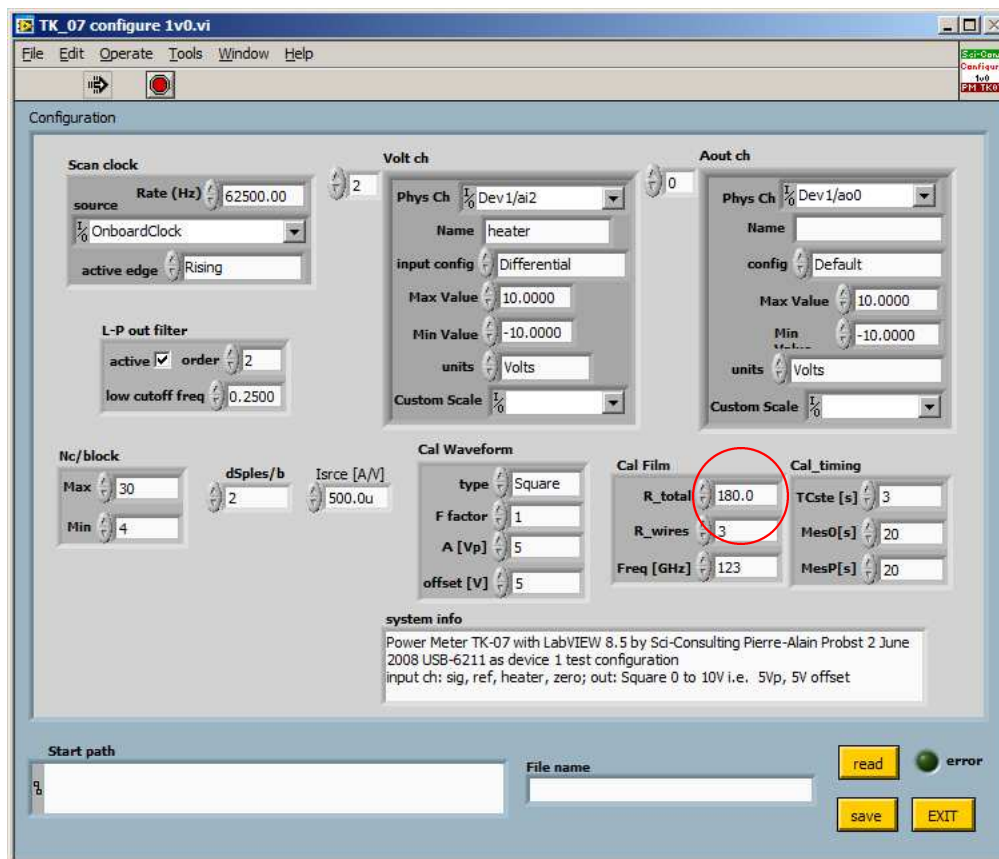

Figure 2.5: Support software configuration, with the film resistance option circled.

7. Click EXIT to close the configuration window.
8. Restarting the software ensures that the required value of the film resistance is made available for subsequent measurements.

**Note** The software need only be configured once. For subsequent runs of the software you need only load the desired configuration file (default is PM TK-07 config dev1.ini) by clicking on Initialize from the menu button.

## 2.3 Calibration

When the program is running without any power incident on the film, a view similar to that in [Figure 2.4](#) is seen when the PowerMeter tab is selected. Note that before calibration, power readings give negative and haphazard profiles of measurement. The device automatically calibrates on startup, thereafter the measurements tail off to zero. Manual calibration can also be activated by clicking on the `cal` button located below the measurement reading on the left hand side of the panel.

- Ensure that the power meter head is switched on, with no signal beam incident upon it.
- Check that the modulation reference is switched on and set to the desired chopping frequency.
- Enter the frequency of the radiation to be measured at the top left of the window (circled in [Figure 2.4](#)).
- For the best performance, the system should be warmed up for at least half an hour, to allow the lock-in amplifier to stabilise.

Calibration proceeds by first monitoring the head output when no signal is present. Next a known square wave of 0.8 V amplitude is injected into the film at the reference modulation frequency. The calibration signal and the head's response to it can be viewed in the Signal & FT tab, and should resemble that shown in [Figure 2.6](#). During this period no THz signal should — of course — be presented to the head. The calibration procedure takes about 3 minutes. If the calibration is unsuccessful the stability of the modulation reference signal should be checked.

After calibration the screen displays the power detected by the head, adjusted for window loss at the specified signal frequency. Proper measurements can then commence. Small deviations of the reference frequency away from that used for calibration are displayed as  $\Delta F_{\text{ref}}[\%]$ . A chart at the right tracks power levels as a function of time. You may exit the program at any time by selecting `Idle (Stop)` from the menu button, then `EXIT` and then closing the window. Note that after `EXIT` has

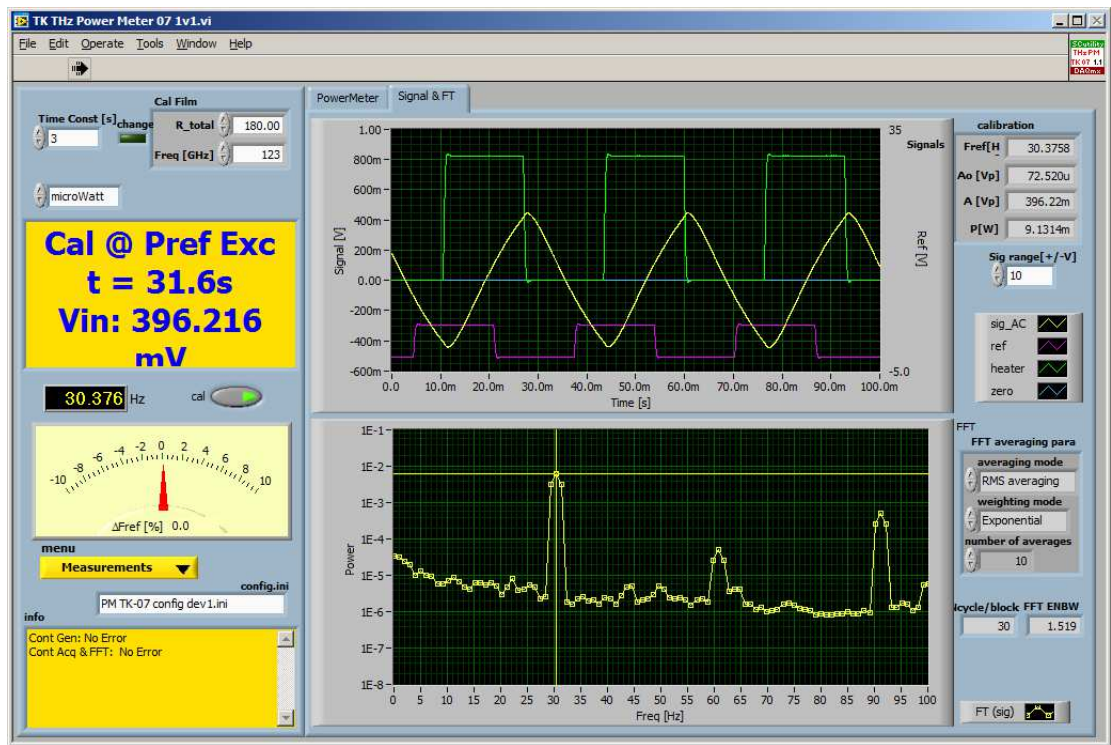

Figure 2.6: The signal and Fourier Transform display during the second stage of a calibration.

been selected, the LabVIEW system will no longer be running the support software. It will therefore not respond unless the Run button in the toolbar is clicked.



## 2.4 Measurement

From the menu button shown by the upper arrow in [Figure 2.4](#), select `Start Measurements`. A number of controls are available with which to adjust the performance of the instrument.

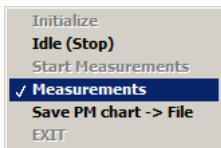

- From the menu button

**Idle (Stop)** pauses the measurement process.

**EXIT** halts the program and can be activated by clicking on the menu icon located in the lower left hand side of the control panel.

**Save PM chart → File** produces a text file of the chart history including the film resistance, frequency of measurement and power versus time data. This can be useful in checking power stability over time.

- The control directly above the power display allows the display to be changed between microwatts and milliwatts.
- The `Time Const [s]` control, located at the top left hand side of the control panel, changes the digital integration time used for the values displayed on the meter and the chart. The software performs a decaying average on the train of measurement values. Increasing the time constant extends the time. The default integration time is 1 s. To alter this, simply edit the number in the input box.
- For the chart
  - Clicking the secondary mouse button on the chart brings up a menu enabling the user to control the appearance of the chart.
  - The button below the graph allows it to be reset.
  - If `AutoScale Y` has been disabled in the chart menu, the power range of the graph can be changed by clicking the scale limits to edit them.

The software also runs a full set of error trapping routines and will indicate faults such as the loss of a lock-in reference signal or a significant

change in the modulation frequency supplied as a reference to the lock-in amplifier. This frequency must remain constant during a measurement session, as the responsivity of the head is dependent upon it. To correct this error the power meter must be calibrated at the new frequency or the reference frequency must be changed back to that used in the initial calibration.

## 2.5 NEP Estimation

The Noise Equivalent Power (NEP) of the power meter system can be determined by looking at the lower trace on the Signal & FT tab. This displays the noise in the system as a function of the frequency multiplied by the root of Equivalent Noise Bandwidth (ENBW). The meter at the left of the window shows the modulation frequency. A guide to the NEP can

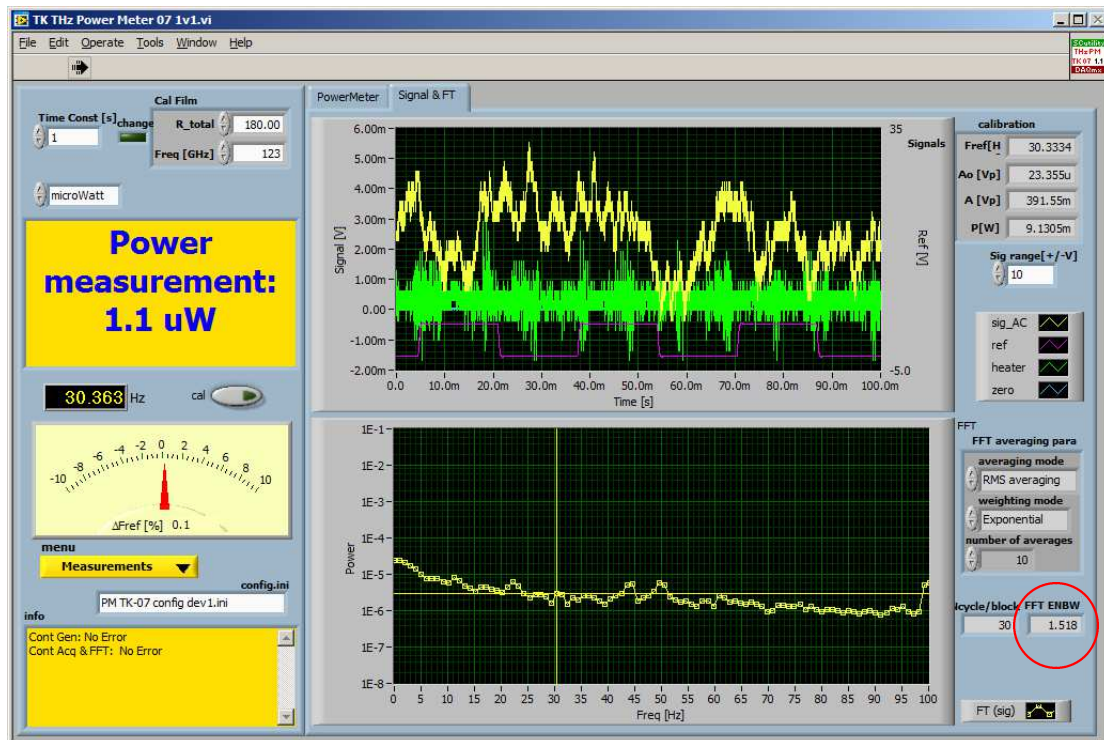

Figure 2.7: The signal and Fourier Transform window, with the Equivalent Noise Bandwidth (ENBW) indicator circled.

be found — in the absence of signal — by looking close by (but not at) the modulation frequency. A precise value requires division by the square root of the ENBW (lower right of the display, see [Figure 2.7](#)). Values of about  $1 \times 10^{-5}$  W are acceptable.

## **Chapter 3**

### **Stand-alone Usage**

## 3.1 Power Measurement

### 3.1.1 Setting Up

The output voltage from the power meter is measured using a lock-in amplifier or spectrum analyser. In the case of a lock-in amplifier, its reference input should be connected to the source of signal modulation. The voltage measured will be proportional to the incident power.

### 3.1.2 Calibration

To calibrate the head, modulated ohmic power is generated in the metallic film. A square-wave current supply is required with a DC offset which can be adjusted so that the current alternates between zero and a constant value which produces about 1 mW of ohmic power in the film. The frequency of the square-wave should be the same as the intended signal modulation frequency. The current is passed through the film via one of the BNC cable connectors and the potential difference across the film is measured via the other as shown in [Figure 3.1](#). The current supply and the DC offset are adjusted so that the voltage across the film alternates between zero and a value near  $\sqrt{10^{-3} R_{\text{film}}}$  which gives a current-on ohmic power close to 1 mW. The potential difference across the film in the current-on periods,  $V_0$ , is then measured and the ohmic power

$$P_0 = \frac{V_0^2}{R_{\text{film}}} \quad (3.1)$$

can be calculated. Note that this is the (peak) power when current is flowing, not the mean power.

The wave-form of the output will be a distorted square wave because the power meter head has a limited response time. The type of instrument used to measure the output voltage will determine whether the value recorded,  $V_{\text{cal}}$ , is the RMS value, the amplitude of the fundamental component, the RMS value of the fundamental component, or some other measure of the output magnitude. The calibration is therefore to be understood as being specific to the use of the power meter head with that particular instrument type, at a particular modulation frequency.

The value of the *internal* responsivity, in units of V/W, of the power meter,  $r_{\text{pi}}$ , is then determined from

$$r_{\text{pi}} = \frac{V_{\text{cal}}}{P_0} = \frac{V_{\text{cal}} R_{\text{film}}}{V_0^2} \quad (3.2)$$

### Example

Film resistance	$R_{\text{film}}$	=	200 $\Omega$
Voltage applied	$V_0$	=	0.8 V
Calibration power	$P_0$	=	$\frac{(0.8)^2}{200} = 3.2 \text{ mW}$

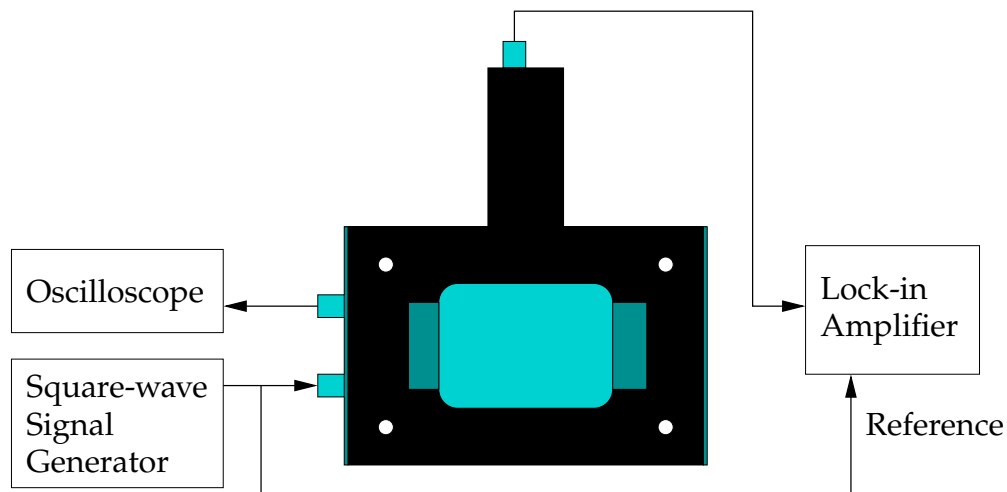

Figure 3.1: Circuit for calibration of the power meter head. An oscilloscope or other peak voltage measuring device attached to the second film connection allows an accurate measurement of the applied voltage,  $V_0$ .

## 3.2 Energy Measurement

The head's time constant is a few milliseconds. Therefore the form of a pulse of radiation which is shorter than a millisecond has no effect on the response of the head to the pulse. In other words, the head sees the pulse as a Dirac delta function.

The head can therefore be used to measure energy in pulsed beams whose pulse width is a millisecond or less and whose pulse repetition rate is lower than 40 Hz. The head's sensitivity (NEJ) is of the order of 1  $\mu\text{J}$ .

### 3.2.1 Setting Up

The head should be placed in the pulsed beam in the same manner as for continuous wave power measurements. The signal from the BNC microphone output should be fed to a digital storage oscilloscope or similar storage device.

Triggering for such a device can often be taken directly from the head's output when large signals are present. If the signal energy is close to the NEJ, however, triggering directly from the source may be necessary.

### 3.2.2 Calibration

Calibration is performed in a similar way to that for power measurement — via ohmic heating of the metallic film. An electrical pulse generator is connected to the film as shown in [Figure 3.2](#). The pulse voltage should ideally be monitored via the second film connection to avoid possible voltage drops across the source output impedance or BNC cables. The electrical energy dissipated in the film is given by

$$E_0 = \frac{V_0^2}{R_{\text{film}}} \times \tau \quad (3.3)$$

where  $\tau$  is the length of the pulse. This should be less than 1 ms and about 250  $\mu\text{J}$  of energy should be generated for calibration.

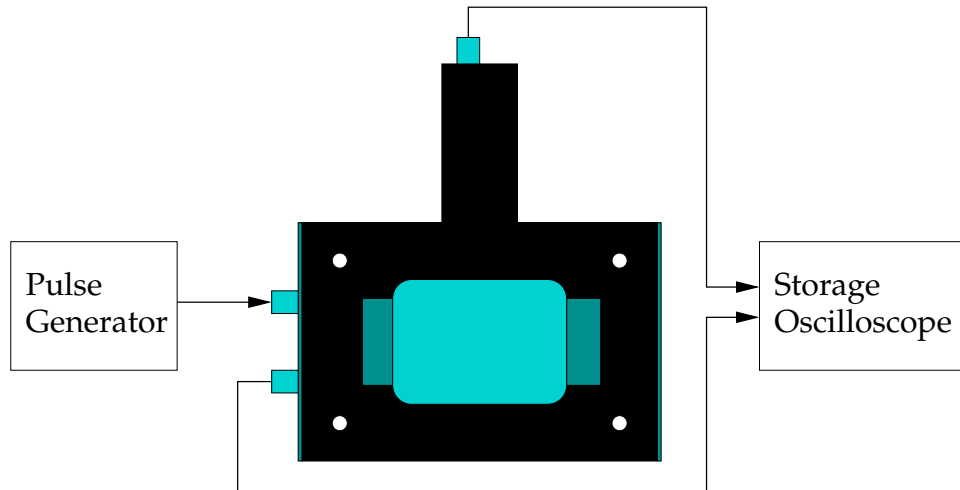

Figure 3.2: Circuit for calibration of the power meter head as an energy meter.

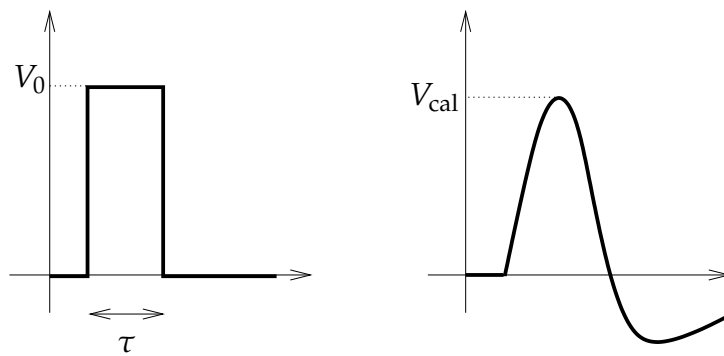

Figure 3.3: Sketch of the response of the power meter head to a pulse of radiation.

The storage oscilloscope should then show a response from the head similar to that given in [Figure 3.3](#). The peak output voltage  $V_{\text{cal}}$  (or alternatively the area under the distorted curve) is then measured using the storage oscilloscope. The value of the *internal* responsivity, in units of V/J, of the power meter,  $r_{\text{ji}}$ , is then determined from

$$r_{\text{ji}} = \frac{V_{\text{cal}}}{E_0} = \frac{V_{\text{cal}} R_{\text{film}}}{V_0^2 \tau} \quad (3.4)$$

### Example

Pulse length	$\tau$	=	0.5 ms
Film resistance	$R_{\text{film}}$	=	150 $\Omega$
Energy required	$E_0$	=	250 $\mu\text{J}$
Voltage required	$V_0$	=	$\sqrt{\frac{E_0 R_{\text{film}}}{\tau}} = \sqrt{\frac{0.25 \times 10^{-3} \times 150}{0.5 \times 10^{-3}}} = 8.66 \text{ V}$

**Note** The voltage  $V_0$  to be used in Equations [3.3](#) and [3.4](#) in calculating the calibration power,  $E_0$ , should be that measured across the film. The output impedance of the signal generator may cause this to be less than that measured across the generator alone when it is not having to drive a current.

### 3.3 External Responsivity

The internal responsivity,  $r_{\text{pi}}$  or  $r_{\text{ji}}$ , can be converted to an *external* responsivity,  $r_e$ , by making allowance for the following factors:

- **Absorption of the film**

The absorption of the metal film is  $49 \pm 2\%$  throughout the submillimetre range — see [chapter 4](#).

- **Transmission of the window**

The transmission,  $T$ , of the TPX window at the Brewster angle falls from 100% below 100 GHz to 53% at 3 THz — see [Appendix B](#).

A measured signal can thus be converted to an absolute power or energy by evaluating

$$P = \frac{V_{\text{lock in}}}{0.49 T \times r_{\text{pi}}} \quad (3.5)$$

or

$$E = \frac{V_{\text{peak or area}}}{0.49 T \times r_{\text{ji}}} \quad (3.6)$$

## **Chapter 4**

# **Troubleshooting and Maintenance**

## Film resistance

Periodic measurement, say, once every six months, of the power meter head's film resistance is advisable, to check that the film has not deteriorated or been damaged by excess incident beam power. The calibration accuracy of the system is based upon a good knowledge of  $R_{\text{film}}$ . If the resistance changes by more than 5%, Thomas Keating Ltd should be informed. A film resistance in the range  $110 \Omega$  to  $230 \Omega$  is acceptable. Theoretical analysis indicates an absorption rising from 48% when  $R_{\text{film}} = 110 \Omega$  to 50% at  $160 \Omega$  and returning to 48% for  $230 \Omega$ . Measurements on such films confirm an absorption of  $49 \pm 2\%$  throughout the submillimetre range.

## Battery

A 9V PP3 type battery powers the pressure transducer and lies in the top section of the power meter head. The transducer draws very little current and will supply power over many weeks of full time operation. However the battery should be replaced, say, once a year. This can be done by removing the cover on the side of the top section which is held by four Philips type screws. Replace the battery and refit the cover.

## Lock-in failure

If there is a time-out error when the software goes through the calibration cycle, one check that should be made is whether the level of the reference voltage is sufficient.

## Full scale

The maximum power that can be measured without reaching full scale deflection is 200 mW. If you wish to measure power higher than this, contact Thomas Keating Ltd. for advice.

# **Appendix A**

## **Software Installation**

## **A.1 PC Requirements**

About 1.1 GB of free space is needed for the installation of the NI-DAQ software and the compiled power meter program. Microsoft Windows 2000, XP or Vista should be installed as the operating system.

If the user is inexperienced in installing peripherals and configuring PC's, it may be useful to obtain advice locally. If this is not available, Thomas Keating Ltd. would be pleased to advise.

## A.2 NI-DAQ

National Instruments' NI-DAQ software is on two auto-run CDs supplied with the board and provides the interface between the A/D hardware and the compiled LabVIEW power meter application.

- On inserting the first CD, the menu shown in [Figure A.1](#) should appear.



Figure A.1: NI-DAQ CD menu.

- Click [Install Software](#), and the installer appears, starting with the product information — [Figure A.2](#).
- The next two installer pages allow the target directory ([Figure A.3](#)) and feature set ([Figure A.4](#)) to be chosen. The default feature selection should be sufficient.
- Follow through the installer, accepting the licence agreements and NI drivers as shown in [Figures A.5–A.7](#).
- Click [Next](#) at the summary page ([Figure A.8](#)) to begin installation, inserting the second CD when it is requested ([Figure A.9](#)).

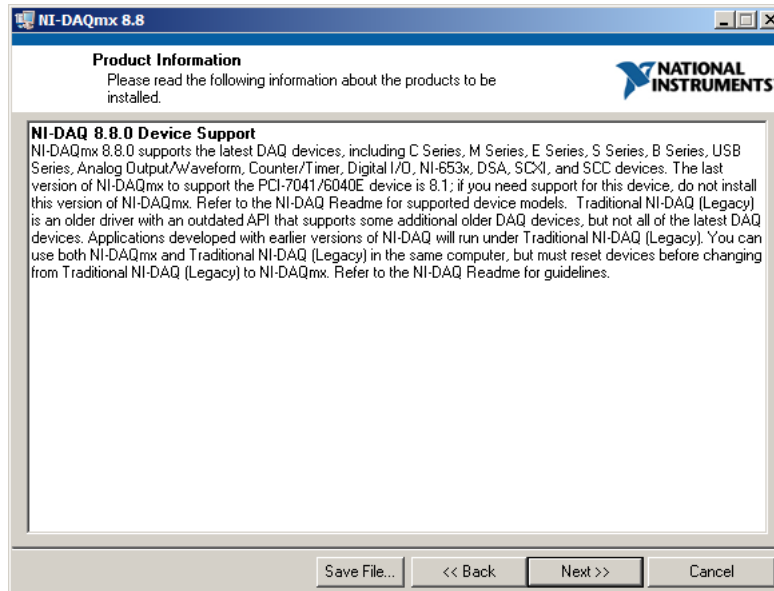

Figure A.2: NI-DAQ product information window.

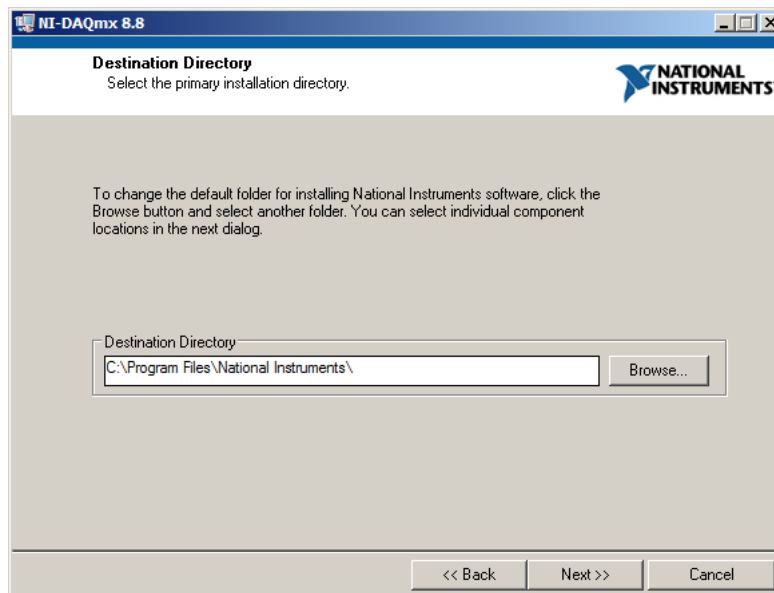

Figure A.3: Directory choice.

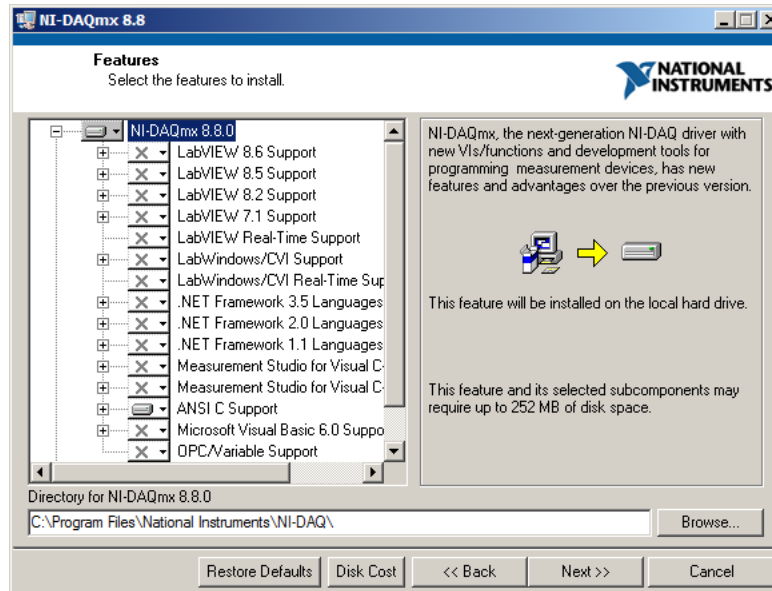

Figure A.4: Feature selection.

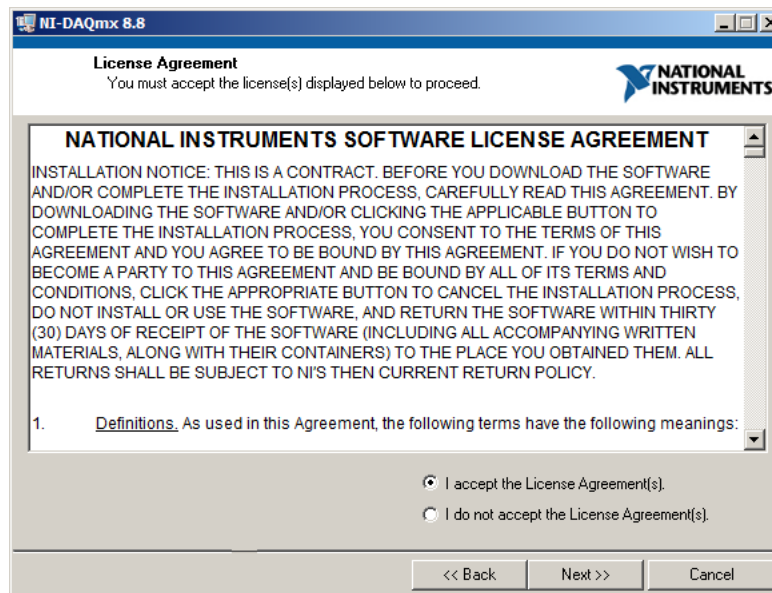

Figure A.5: NI-DAQ licence window.

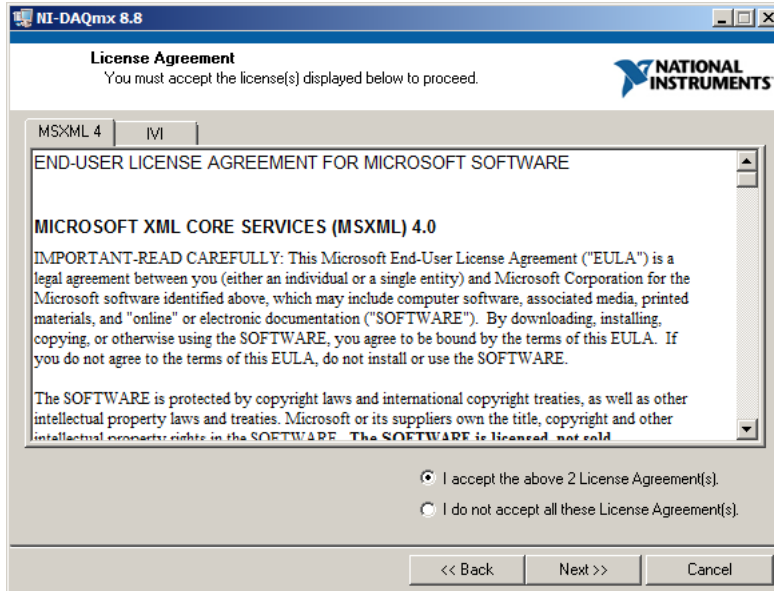

Figure A.6: Second licence agreement window.

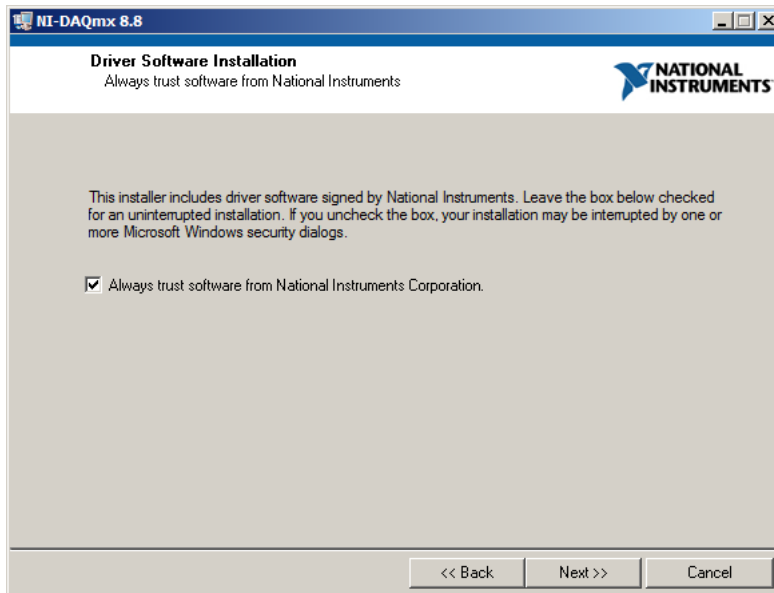

Figure A.7: NI driver acceptance window.

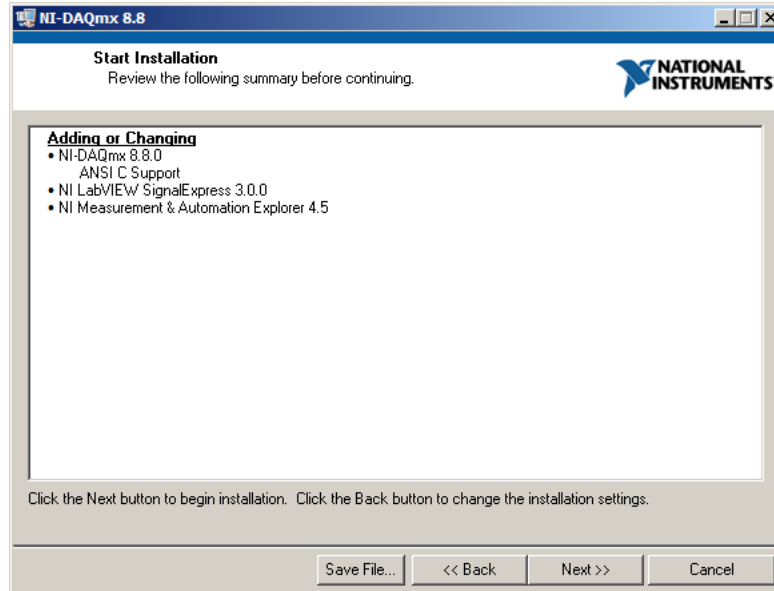

Figure A.8: Installation summary.

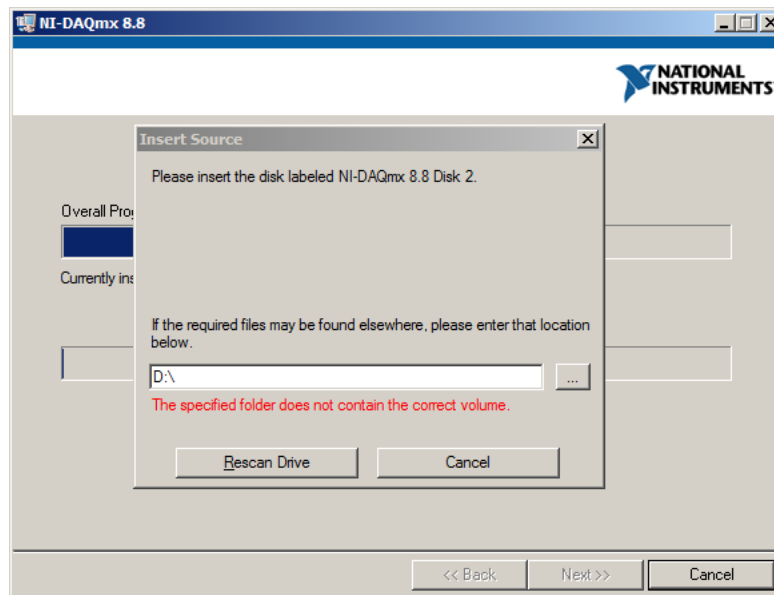

Figure A.9: CD 2 prompt.

- After the installation is complete (Figure A.10) the PC should be rebooted (Figure A.11) to ensure that the drivers will be available when the support unit is connected to the PC.

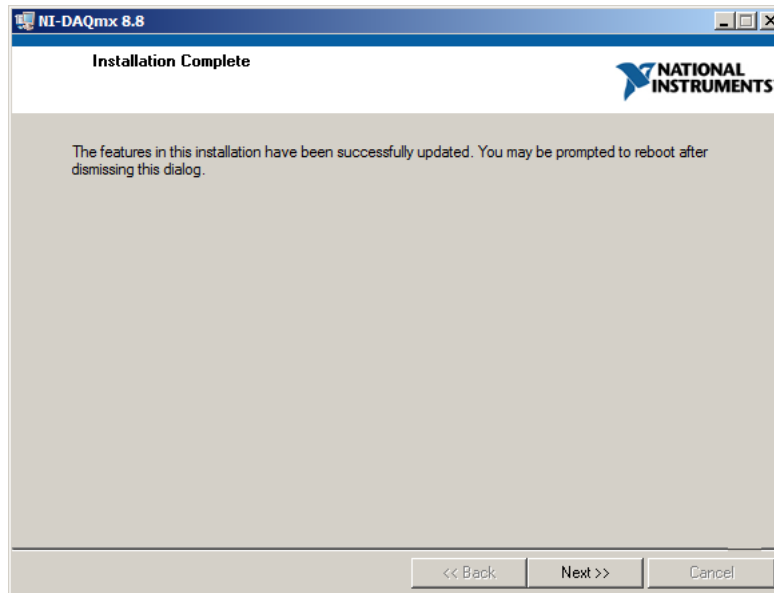

Figure A.10: Completion window.

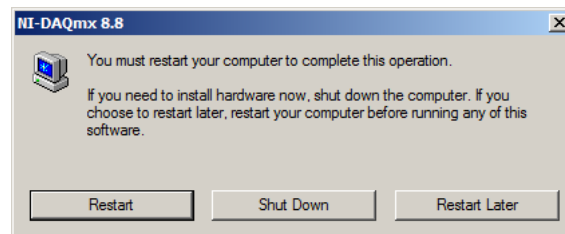

Figure A.11: Reboot request.

## A.3 Support Software

The power meter support software is included on the CD supplied with the support Unit.

- When the CD is inserted, the installer should start automatically, with the component selection panel shown in [Figure A.12](#).

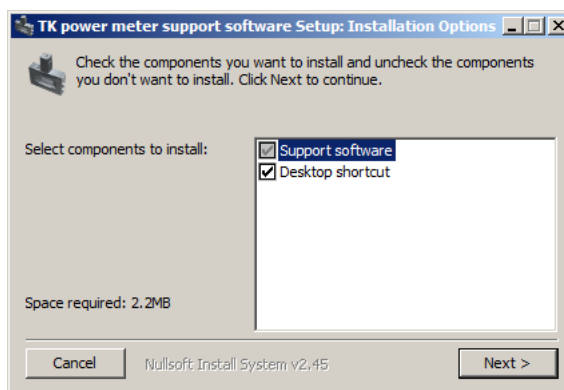

Figure A.12: Support software component selection.

- A second panel ([Figure A.13](#)) allows the destination directory to be chosen.

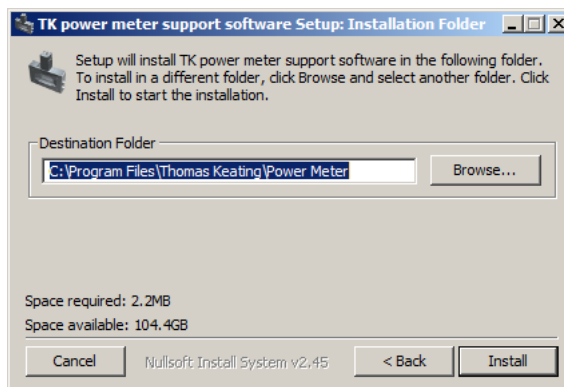

Figure A.13: Installation directory choice.

The CD also contains a copy of the software in the archive file `TK07_20080609.zip` and a copy of this manual in PDF format. These can be used as an alternative to the automated installer by right-clicking the ZIP file and using the `Extract all` command.

# **Appendix B**

## **Window Transmission**

## B.1 Factory Measurements

The transmission of the TPX window has been measured from 100 GHz–2.3 THz. The transmission is plotted in [Figure B.1](#). The support software calculates the transmission coefficient by linear interpolation of the data show in [Table B.1](#).

## B.2 Measurement Method

It is possible to use the power meter to make measurements above 3 THz, beyond the range of the transmission look-up table. Users who wish to do this should request a calibrating TPX window from Thomas Keating Ltd, which will be supplied free of charge. This window is a copy of the window of the power meter head, with identical thickness.

The meter is set up as outlined in the standard instructions, at the

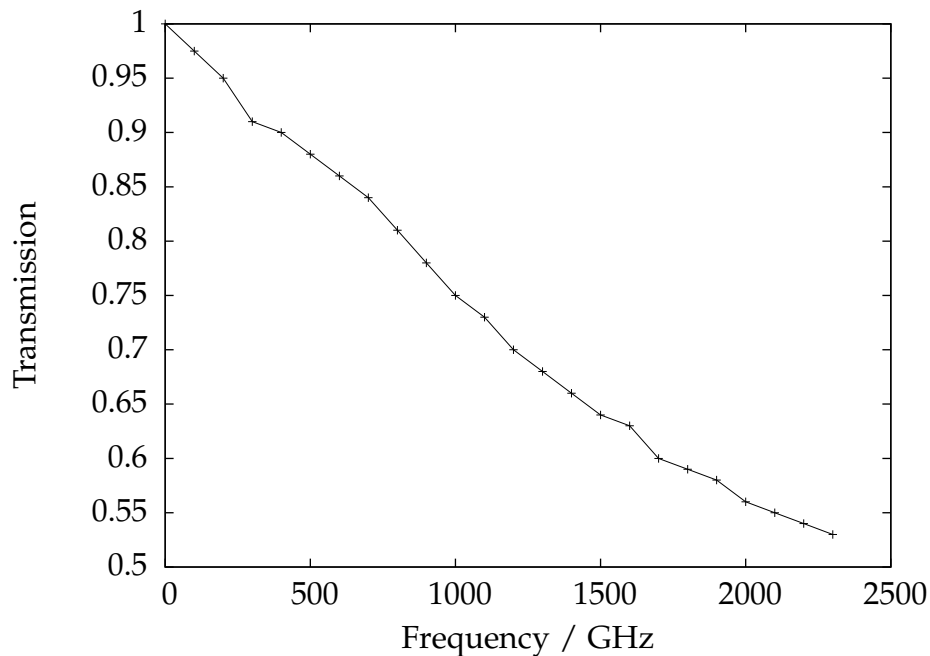

Figure B.1: Window transmission as a function of frequency.

Frequency $\nu/\text{GHz}$	Transmission $T$
0	1.000
100	0.975
200	0.950
300	0.910
400	0.900
500	0.880
600	0.860
700	0.840
800	0.810
900	0.780
1000	0.750
1100	0.730
1200	0.700
1300	0.680
1400	0.660
1500	0.640
1600	0.630
1700	0.600
1800	0.590
1900	0.580
2000	0.560
2100	0.550
2200	0.540
2300	0.530

Table B.1: Window transmission look-up table.

Brewster angle to the source under test. If the support software is being used, the frequency parameter should be set to 100 GHz, where the TPX window is essentially lossless. A power measurement,  $P_0$ , should be made.

Then with the additional window inserted in the beam, close to the head, and also at the Brewster angle, a second power measurement,  $P_1$ , is taken. A reduction of the measured power should be observed, and power values both with and without the additional TPX window recorded. The ratio

$$\alpha = \frac{1}{T} = \frac{P_0}{P_1} \quad (\text{B.1})$$

can then be used to multiply a measured power (with the software configured for 100 GHz) to obtain the absolute power in the beam.

$$P_{\text{absolute}} = \alpha P_{\text{measured}} \quad (\text{B.2})$$

### Example

Without extra window	$P_0$	=	7.3 mW
With extra window	$P_1$	=	3.2 mW
“Window loss” calibration factor	$\alpha$	=	2.28

### Bandpass filters

Should a bandpass/lowpass filter be used to exclude frequencies from being detected by the power meter, an additional calibration factor will need to be introduced, being the reciprocal of the filter’s transmission at the desired frequency of operation.

### Example

Transmission of the filter	$T_F$	=	0.83
“Filter loss” calibration factor	$T_F^{-1}$	=	1.205
Combined calibration factor	$\alpha'$	=	$\alpha \times T_F^{-1} = 2.75$

### B.3 Broadband Transmission

When the signal bandwidth is very large, the window transmission may vary significantly over the band. Denoting the signal power spectrum as  $p(\nu)$  the average transmission can be expressed as

$$\bar{T} = \frac{1}{\alpha} = \frac{\int_{\text{band}} p(\nu)T(\nu)d\nu}{\int_{\text{band}} p(\nu)d\nu} \quad (\text{B.3})$$

# Acknowledgements

All manufacturers' trademarks are acknowledged. Thomas Keating Ltd. would like to thank Prof. Derek Martin of QMW, University of London, who devised the photo-acoustic techniques used in the Power Meter, and Dennis Moss of the UK National Physical Laboratory for advice in the design of the System.

The LabVIEW support software was developed jointly by Thomas Keating Ltd. and Scientific Consulting.

Sci-Consulting Sàrl  
78 ch. du Bochet  
CH-1025 St-Sulpice  
Switzerland

Phone +41 (0)21 697 0761  
Fax +41 (0)21 697 0762

<http://www.sci-consulting.ch/>

# Index

- Bandwidth, 44
- Battery, 29
- Brewster angle, 5
- Broadband, 44
- Calibration, 15
  - energy, 24
  - external responsivity, 27
  - power, 22
- Configuration, 13
- ENBW, 19
- Film
  - absorption, 27
  - resistance, 29
    - measurement, 4
- Filter, 43
- Frequency
  - deviation, 15, 19
  - modulation, 4
  - range, 2
  - signal, 13, 15
- Lock-in amplifier, 22
- NEJ, 2
- NEP
  - measurement, 19
  - typical, 2
- Power
  - full scale deflection, 29
  - maximum, i
- Pulse, 24
  - maximum energy, i
- Save, 18
- Storage oscilloscope, 24
- Triggering, 24
- Window
  - reflection, 5
  - transmission, 4, 41